

| | | | | |
|----|-------------|-----------------|-------------|------|
| 03 | CENTER PIN | PHOSPHOR BRONZE | NICKEL/GOLD | 1 |
| 02 | INSULATOR | TEFLON | NONE | 1 |
| 01 | BODY | BRASS | NICKEL/GOLD | 1 |
| NO | DESCRIPTION | MATERIAL | FINISH | Q'TY |

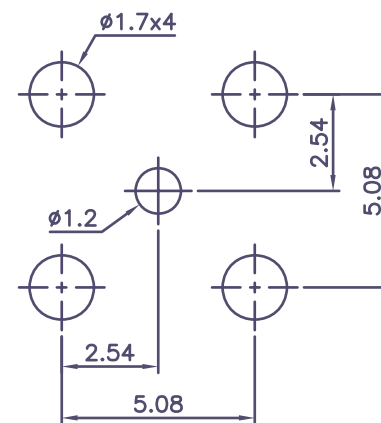
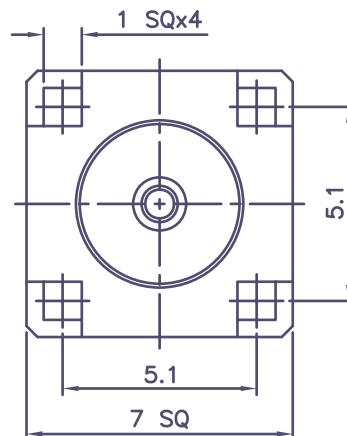
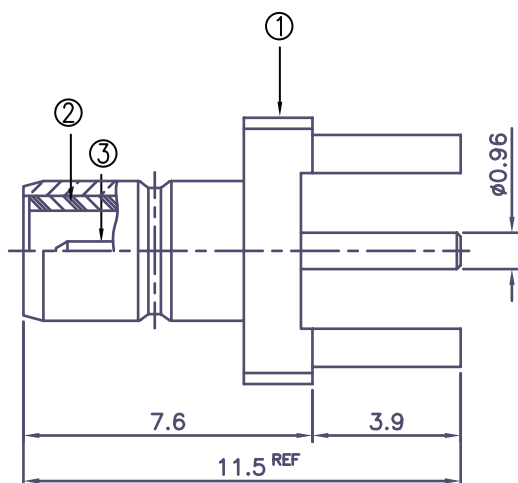

RECOMMENDED PCB LAYOUT DIMENSIONS

Notes:

1. Brass per QQ-B-626
2. Teflon Mil-P-29468
3. Gold Flash plating 3u" Min over
70 u" nickel Min over Copper
4. Gold 30u" over 70u" Nickel Over Copper

HOW TO ORDER:

C 2 0 0 - 5 5 0 0 - 0 0 0 0 - Z

RoHS
COMPLIANT

| Rev | Description | Drawn | Checked | Approved | Date |
|-----|-------------|-------|---------|----------|---------|
| 0 | Issued | BS | S.M. | S.M. | 8/30/11 |
| | | | | | |
| | | | | | |

SMP TECHNOLOGY, INC.

SMB Connector; Vertical ; 50 Ohm

SCALE: N/A

| | | | | |
|-----------|-----------------------------|-------------------------------|--------------|----------|
| TOL. DEC. | 0.5-6 = ±0.2 6-30 = ±0.4 | 30-120 = ±0.6 120-315 = ±1 | ANGLE +/- 3° | UNIT: mm |
|-----------|-----------------------------|-------------------------------|--------------|----------|

P/N: C200-5500-0000-Z