

MATERIAL:

HOUSING: High Temp Thermo Plastic; LCP; Black; UL 94-V-0
 CONTACT: Phosphor Bronze
 CONTACT PLATING: Specified Au Thickness in Contact Area,
 Au Flash on Solder Tail Over 50u" Nickel Subplate
 METAL LATCH: Stainless Steel SUS301

ENVIRONMENTAL:

OPERATING TEMPERATURE: - 40°C +85°C
 STORAGE TEMPERATURE: - 40°C +85°C

ELECTRICAL:

CURRENT RATING :0.5A per Pin
 VOLTAGE RATING; 25 V AC/DC
 CONTACT RESISTANCE:60 mohms
 INSULATION RESISTANCE; 500M Ohms
 DIELECTRIC WITHSTANDING VOLTAGE:125 VAC

HOW TO ORDER:

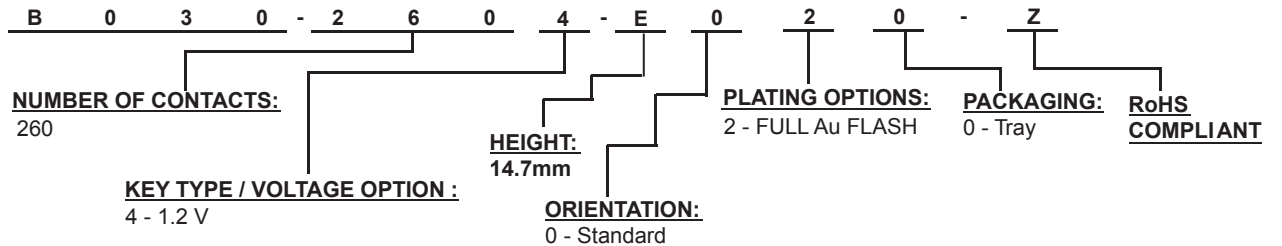

Rev	Description	Drawn	Checked	Approved	Date
0	Issued	B.S.	S.M.	S.M.	07/15/15
A	Latch	B.S.	S.M.	S.M.	03/17/16

SMP TECHNOLOGY, INC.

DDR 4 SO-DIMM Socket, Vertical, 1.2 V; 260 Position, Surface

Mount PC Tails, 14.7mm Height, Standard Orientation

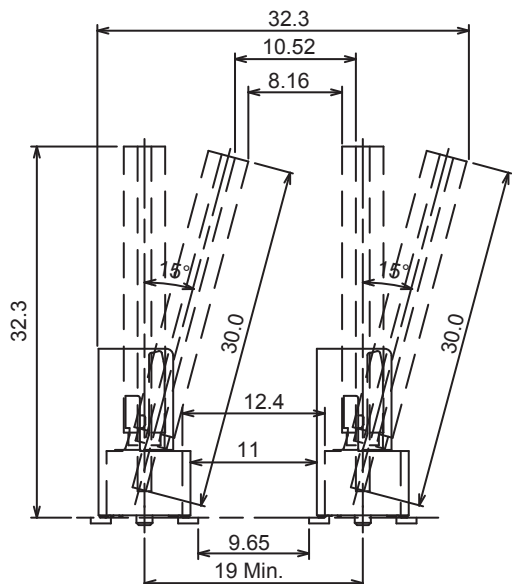

Standard / Standard Orientation

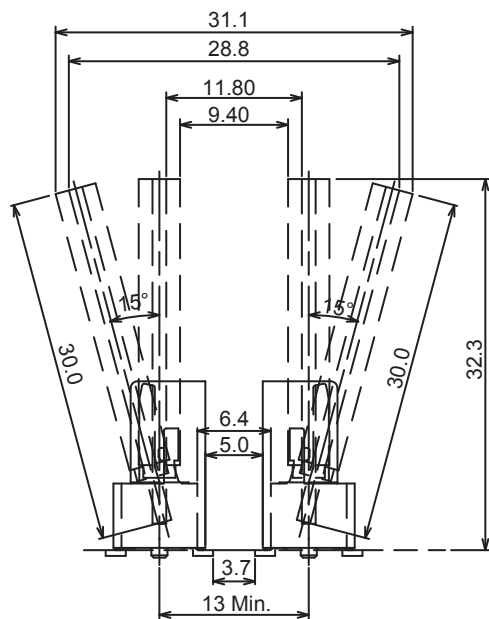

Standard / Reverse Orientation

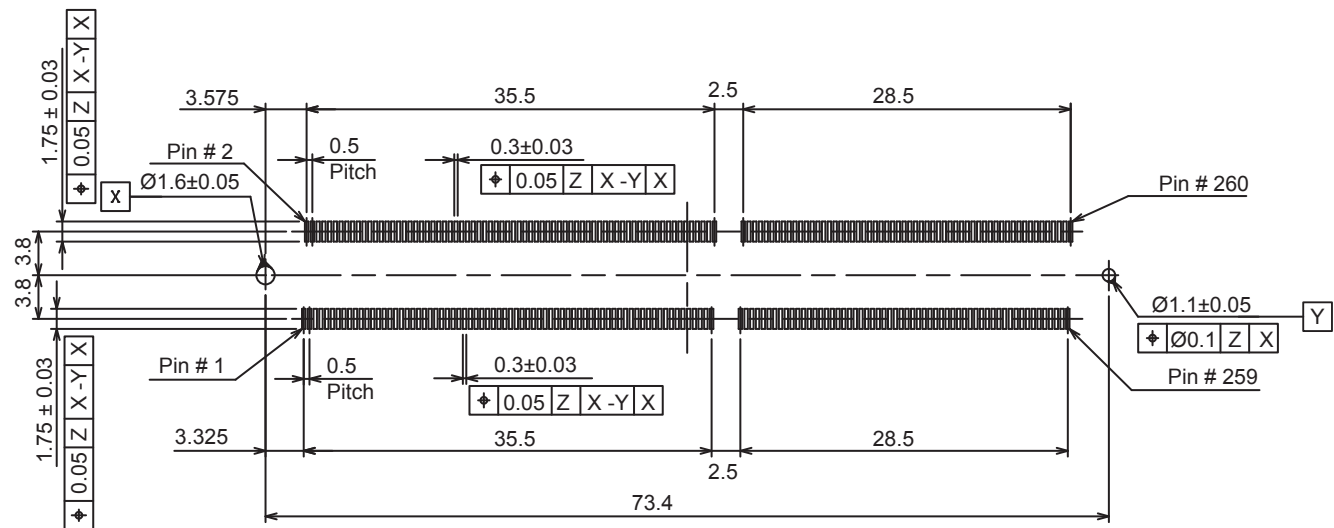

Recommended PCB Layout
(Component Side)

SMP TECHNOLOGY, INC.

DDR 4 SO-DIMM Socket, Vertical, 1.2 V; 260 Position, Surface

Mount PC Tails, 14.7mm Height, Standard Orientation

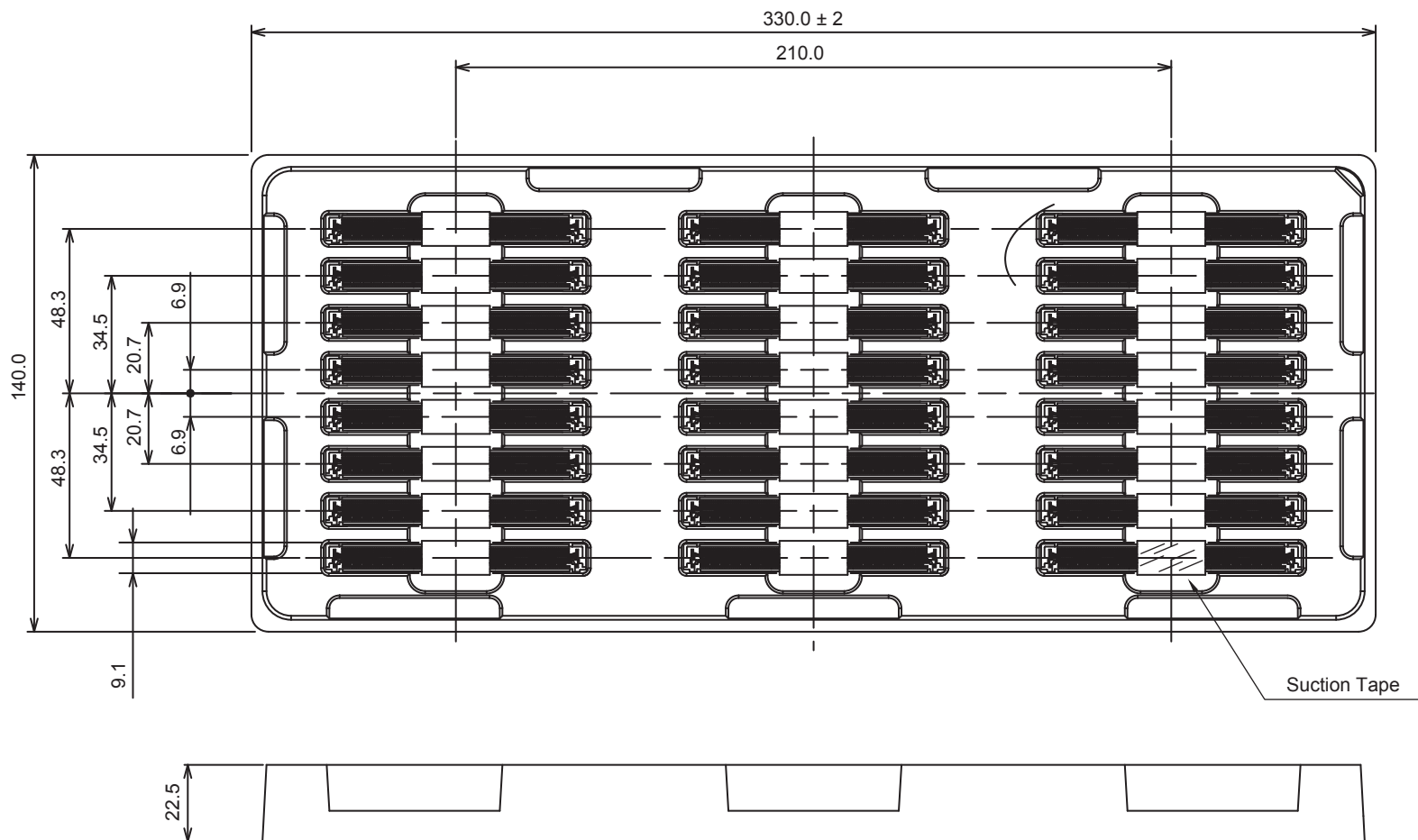

NOTE:
 8X3=24 PCS / TRAY
 6 TRAY / INNER BOX
 3 INNER BOX/ CARTON
 24X6X3=432 PCS/ CARTON

Suction Tape

Packaging Configuration

SMP TECHNOLOGY, INC.

DDR 3 SO-DIMM Socket, Vertical, 1.2 V; 260 Position, Surface

Mount PC Tails, 14.7mm Height, Standard Orientation