

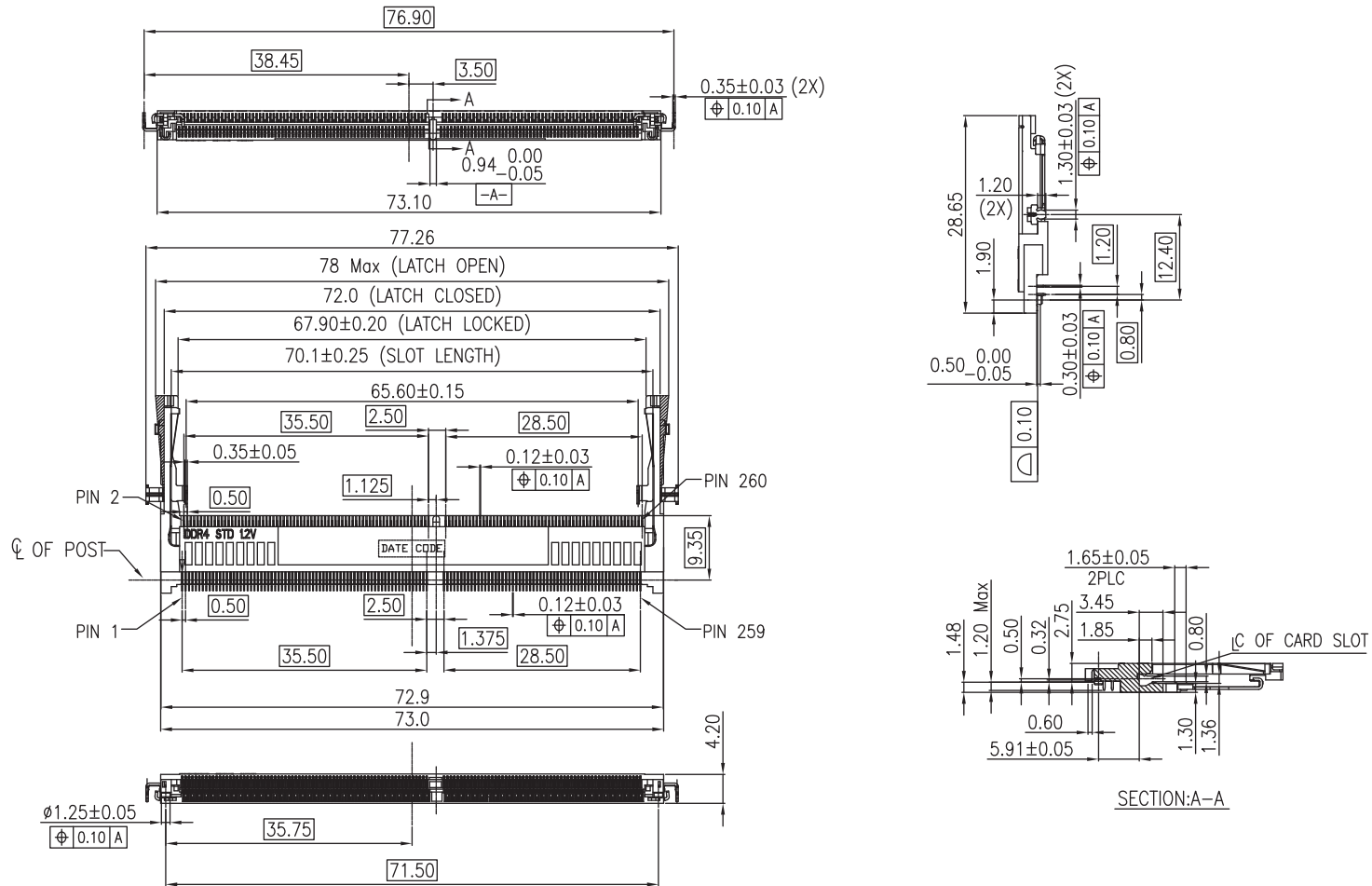

LEAD FREE



HOW TO ORDER:

B 0 3 0 - 2 6 0 4 - 6 5 X X - Z HF

NUMBER OF CONTACTS:

260

HEIGHT OPTION:

6 - 4.0mm

ORIENTATION:

5 - Standard
With 1.48mm
Offset

CONTACT AREA PLATING:

2 - Full Au Flash
5 - 10µ" Au
6 - 15µ" Au
8 - 30µ" Au

RoHS COMPLIANT

PACKAGING:

0 - Tray
1 - Tape & Reel (Normal)
2 - Tape & Reel (Reverse)

HALOGEN FREE

KEY TYPE / VOLTAGE OPTION:

4 - 1.2 Volt

MATERIAL:

HOUSING: High Temp Thermo Plastic UL94V-0, Black
LATCH: Stainless Steel
CONTACT: Phosphor Bronze
CONTACT PLATING: Specified Au Thickness in Contact Area,
Au Flash on Solder Tail Over 50µ" Nickel Subplate

Rev	Drawn	Checked	Approved	Date
0	B.S.	S.M.	S.M.	11/04/15
TOL. DEC.	.X +/- 0.35	.XX +/- 0.25	.XXX +/- 0.15	ANGLE +/- 3° UNIT: mm

SMP TECHNOLOGY, INC.

DDR 4 SO DIMM Socket, 260 Position, 1.2Volt,

Reverse Orientation, 4.00mm Height with 1.48mm Offset Mounting

P/N: B030-2604-65XX-ZHF

Pg: 1 of 4

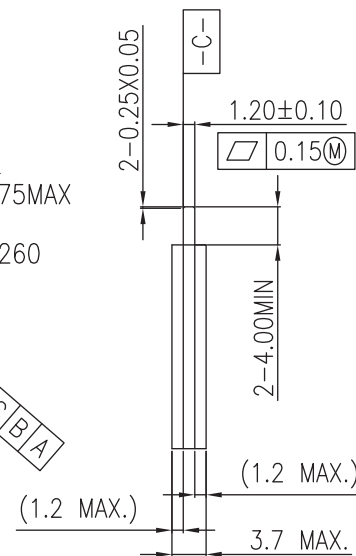
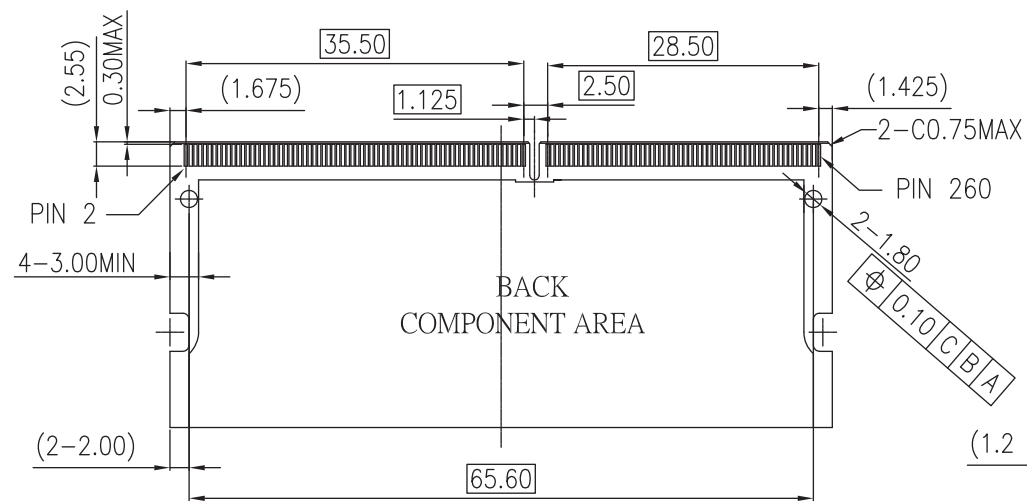
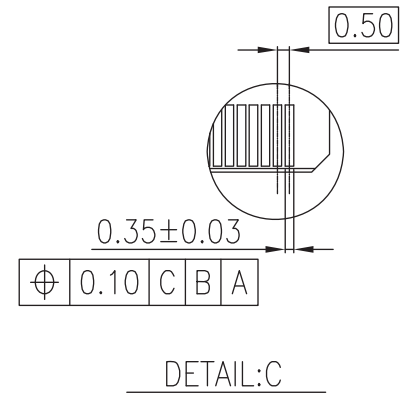
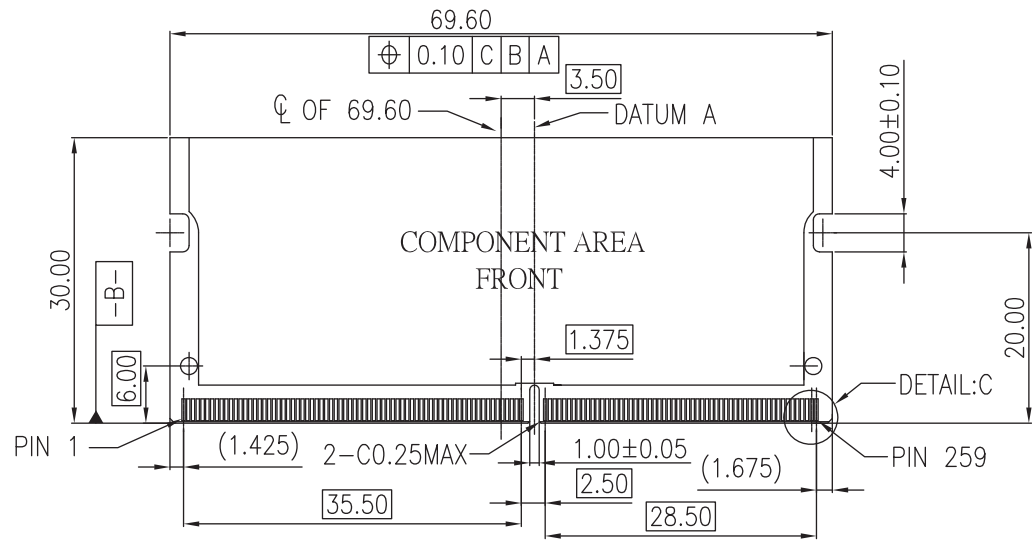

SMP TECHNOLOGY, INC.

DDR 4 SO DIMM Socket, 260 Position, 1.2Volt,

Reverse Orientation, 4.00mm Height with 1.48mm Offset Mounting

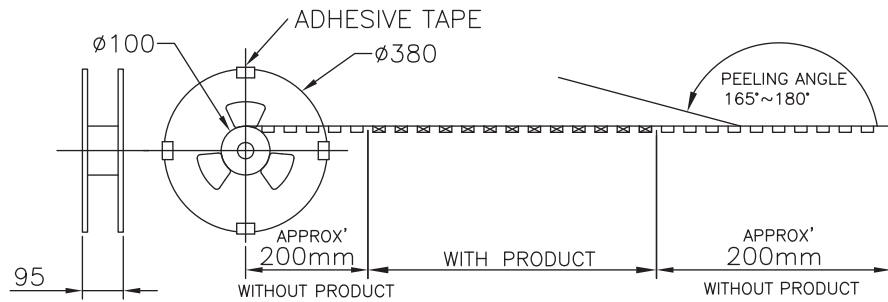

PULL OUT DIRECTION

Notes:
1. 450 Pcs / Reel, 2 Reels / Carton

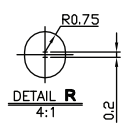
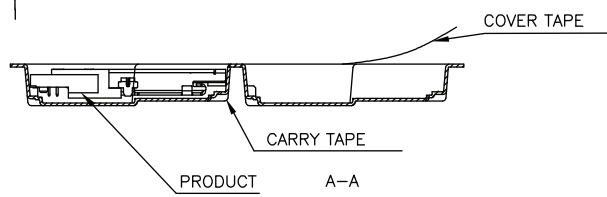
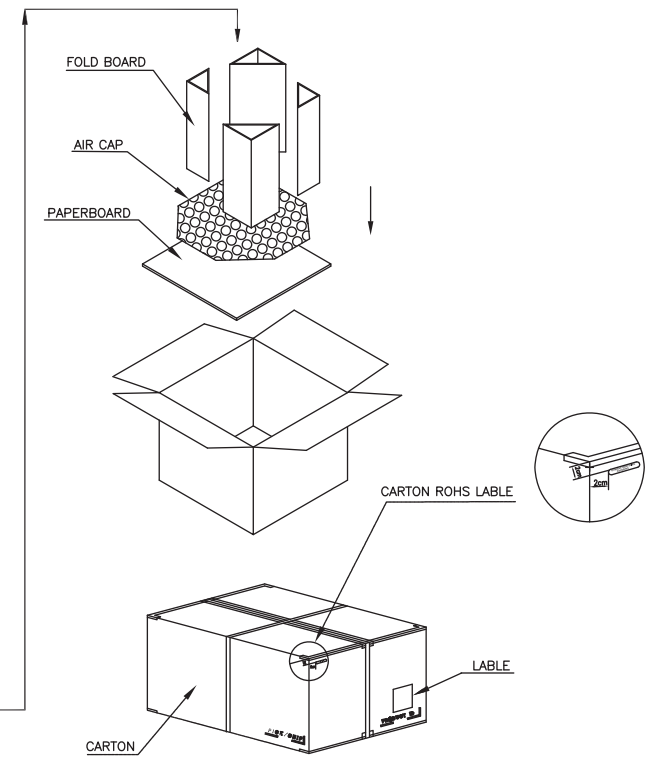
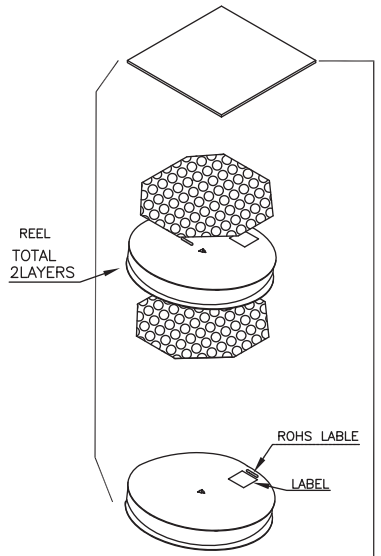
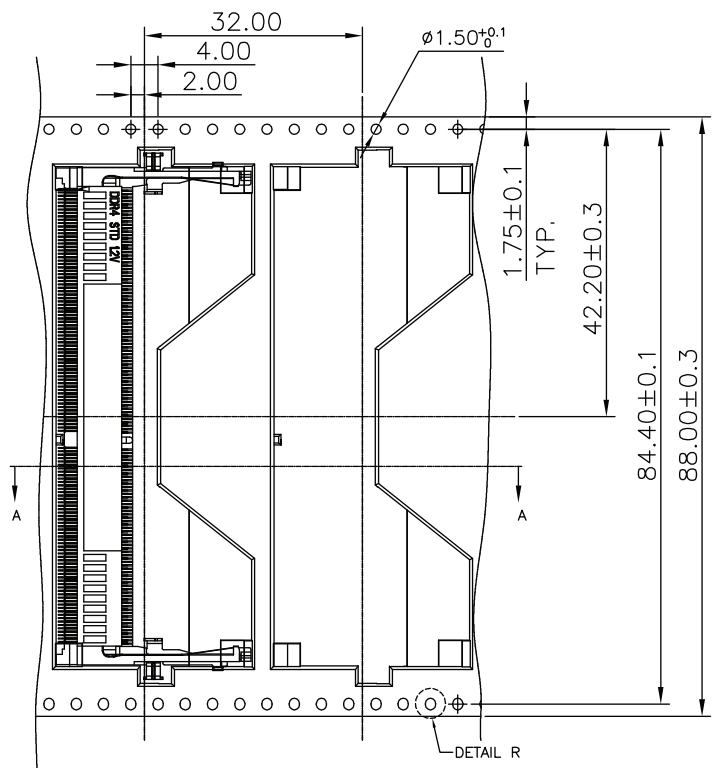

SMP TECHNOLOGY, INC.	
DDR 4 SO DIMM Socket, 260 Position, 1.2Volt,	
Reverse Orientation, 4.00mm Height with 1.48mm Offset Mounting	
P/N: B 0 3 0 - 2 6 0 4 - 6 5 X X - Z H F	Pg: 4 of 4