

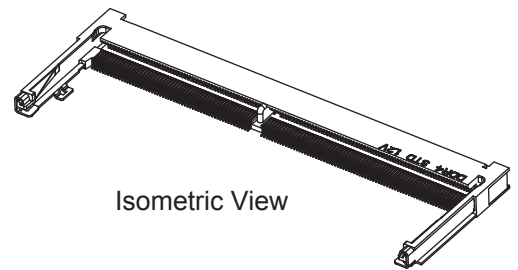

LEAD FREE

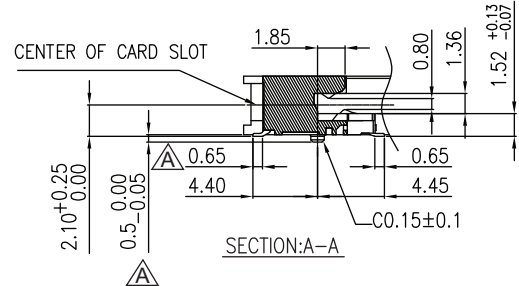

Isometric View

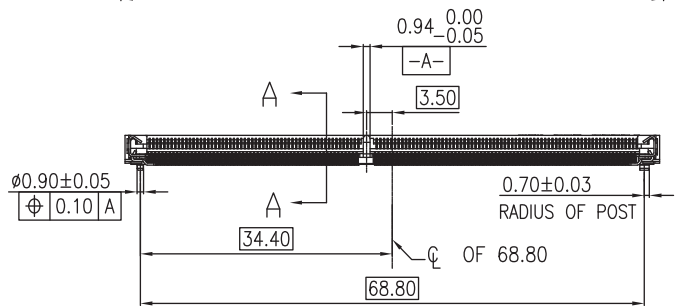
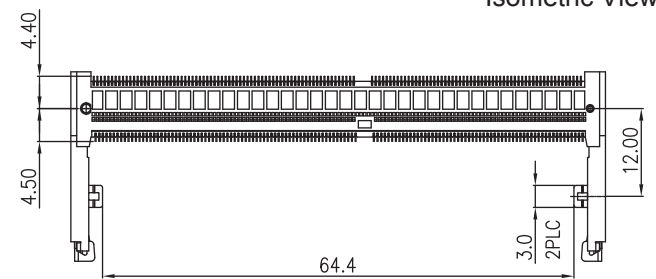
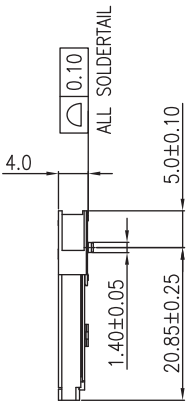
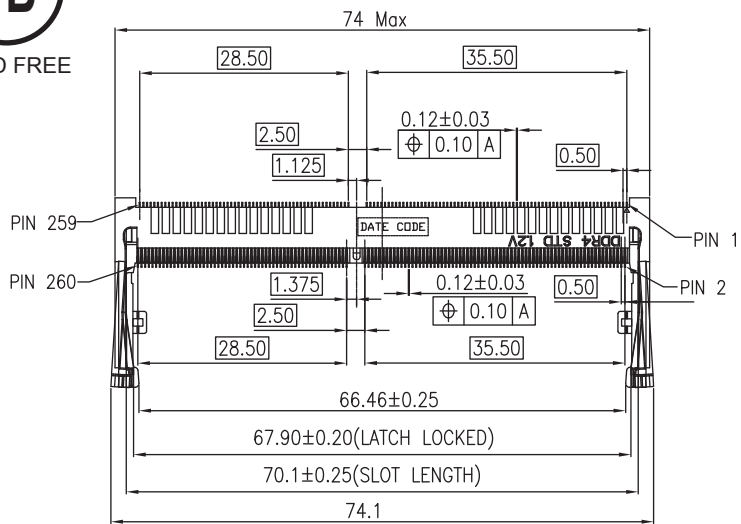

HOW TO ORDER:

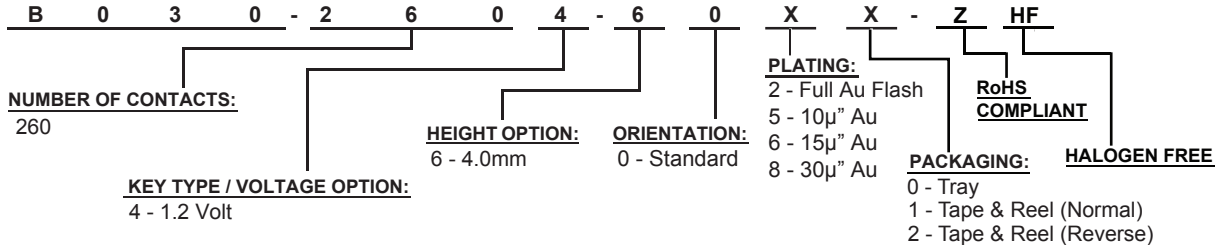

MATERIAL:

HOUSING: High Temp Thermo Plastic UL94V-0, Black
 LATCH: Stainless Steel
 CONTACT: Phosphor Bronze
 CONTACT PLATING: Specified Au Thickness in Contact Area,
 Au Flash on Solder Tail Over 50µ" Nickel Subplate

Rev	Drawn	Checked	Approved	Date
0	B.S.	S.M.	S.M.	09/24/14
A	B.S.	S.M.	S.M.	04/07/16

SMP TECHNOLOGY, INC.

DDR 4 SO DIMM Socket, 260 Position, 1.2Volt,
 Standard Orientation, 4.0mm Height, Type A

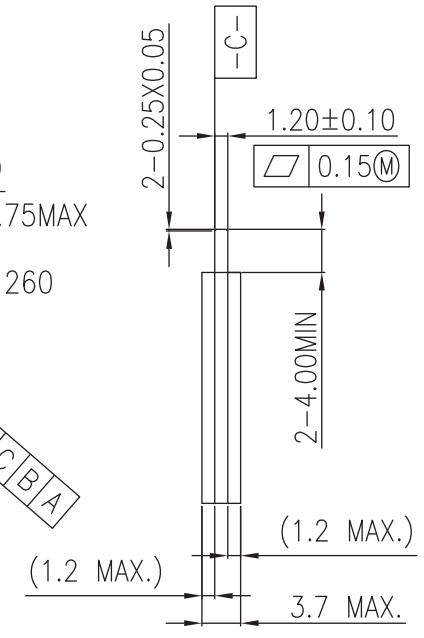
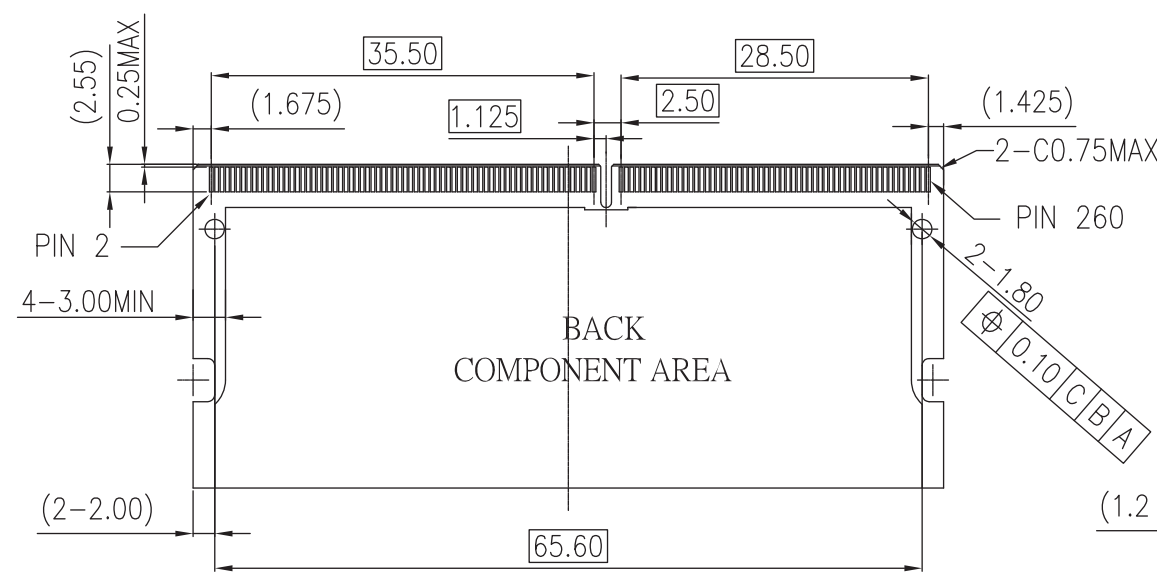
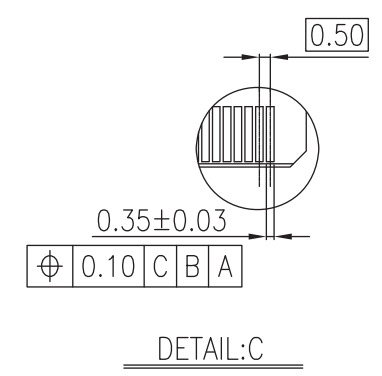
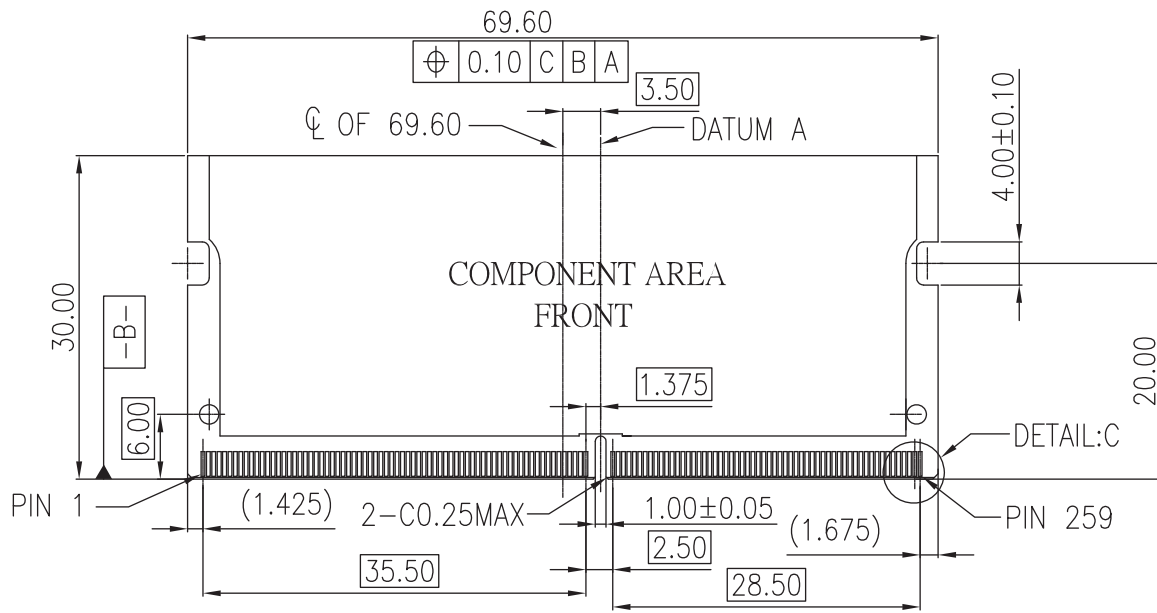

SMP TECHNOLOGY, INC.
 DDR 4 SO DIMM Socket, 260 Position, 1.2Volt,
 Standard Orientation, 4.0mm Height, Type A

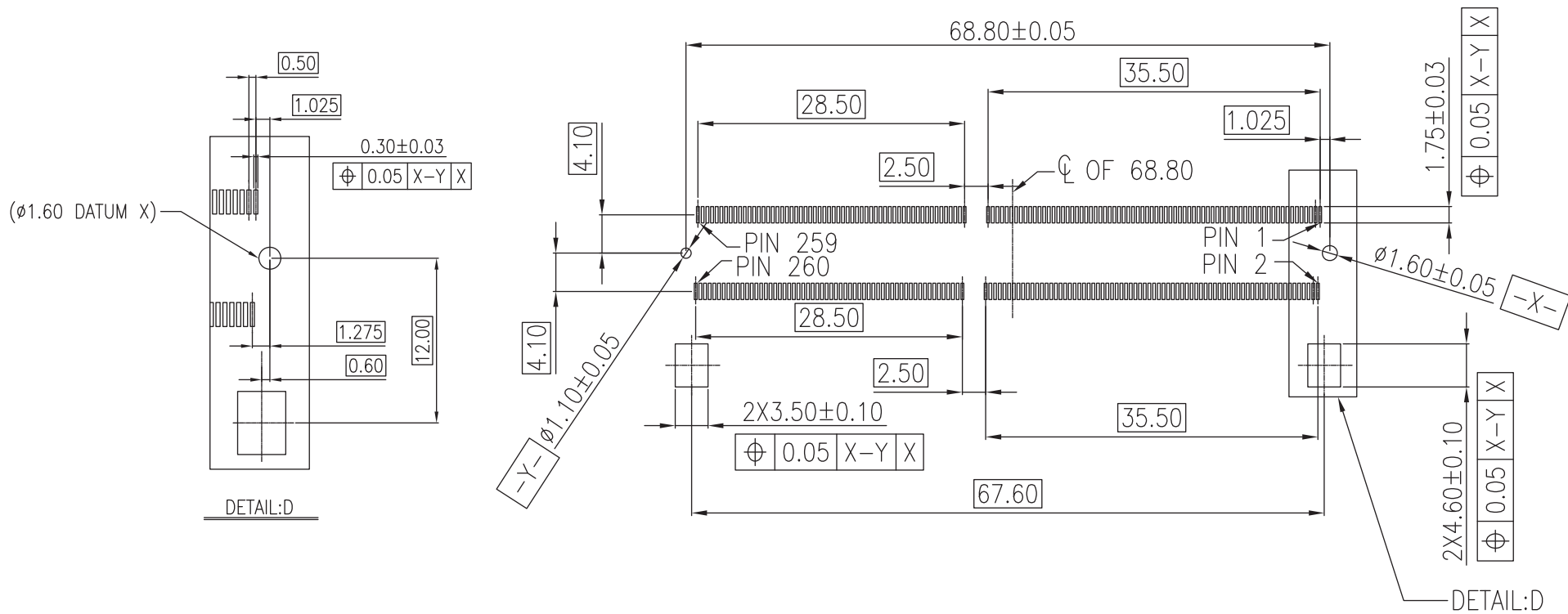

RECOMMENDED PCB LAYOUT

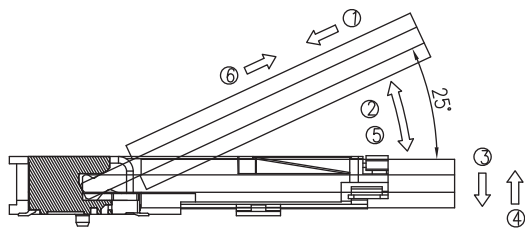

MATING/UNMATING VIEW
SCALE 2:1

- MATING: ① INSERTING(30°) — ② ROTATING — ③ FIXED
UNMATING: ④ UNFIXED — ⑤ ROTATING — ⑥ WITHDRAWING

SMP TECHNOLOGY, INC.
DDR 4 SO DIMM Socket, 260 Position, 1.2Volt,
Standard Orientation, 4.0mm Height, Type A

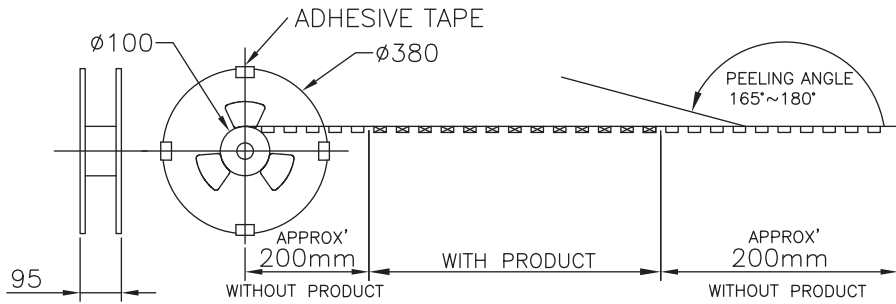

Notes:

1. 450 Pcs / Reel, 2 Reels / Carton
2. Net Weight / Carton: 3.13Kg
3. Gross Weight / Carton: 5.26Kg

PULL OUT DIRECTION →

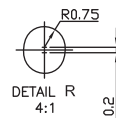
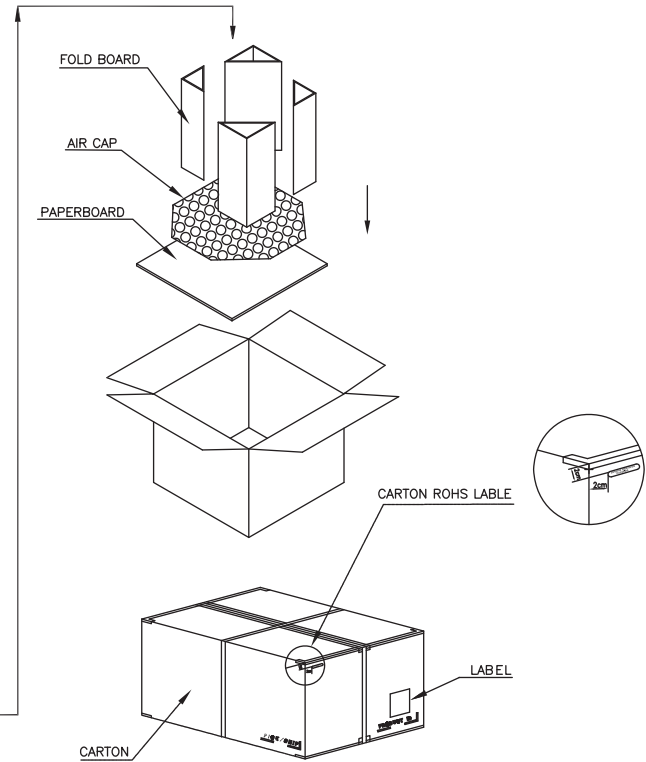
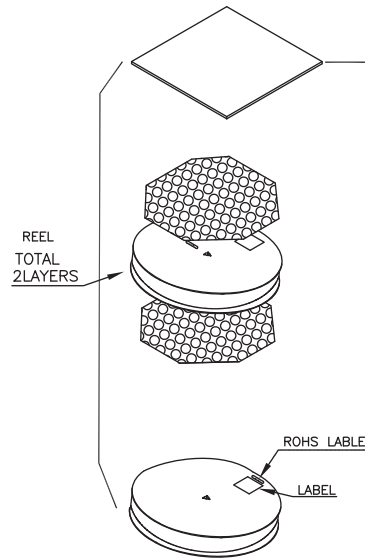
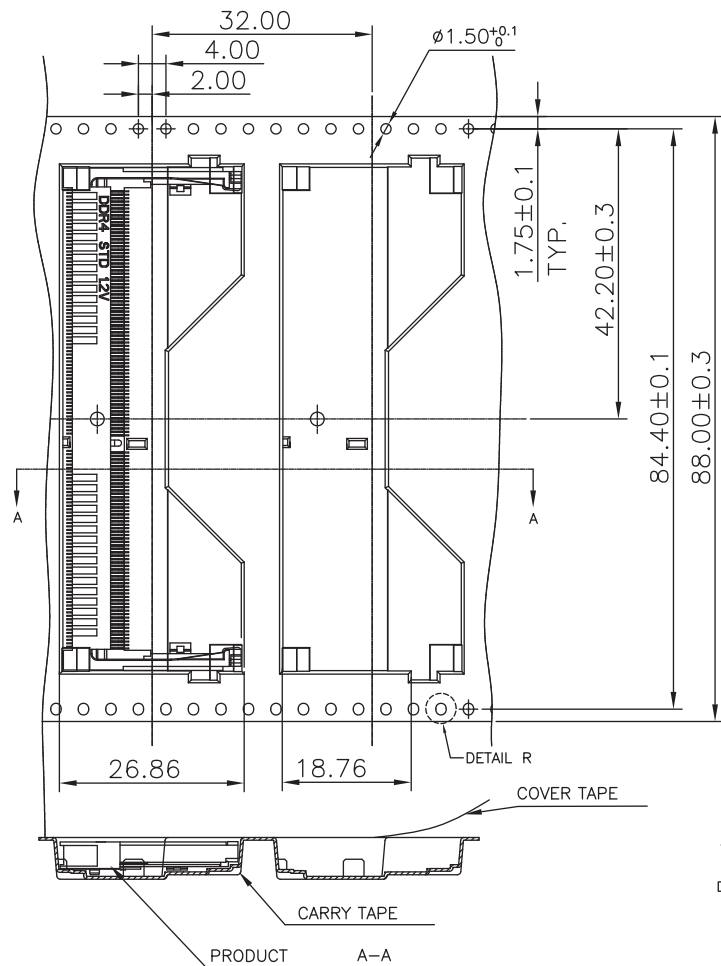

SMP TECHNOLOGY, INC.

DDR 4 SO DIMM Socket, 260 Position, 1.2Volt,
Standard Orientation, 4.0mm Height, Type A